

# Laser Light Barrier

## Operating Manual

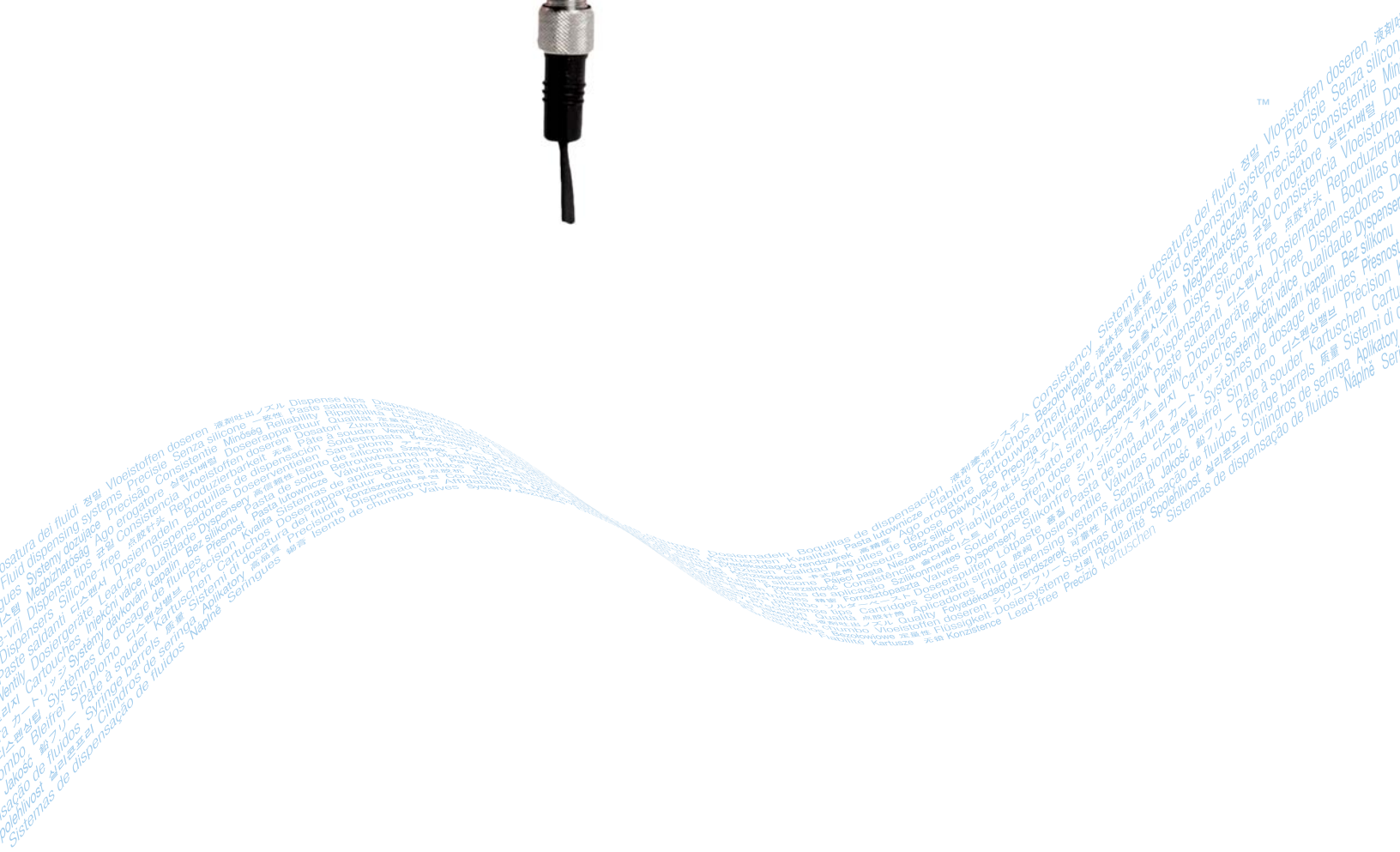

Electronic pdf files of Nordson EFD manuals are also available at [www.nordsonefd.com](http://www.nordsonefd.com)



You have selected a reliable, high-quality dispensing system from Nordson EFD, the world leader in fluid dispensing. The Laser Light Barrier was designed specifically for industrial dispensing and will provide you with years of trouble-free, productive service.

This manual will help you maximize the usefulness of your Laser Light Barrier.

Please spend a few minutes to become familiar with the controls and features. Follow our recommended testing procedures. Review the helpful information we have included, which is based on more than 50 years of industrial dispensing experience.

Most questions you will have are answered in this manual. However, if you need assistance, please do not hesitate to contact EFD or your authorized EFD distributor. Detailed contact information is provided on the last page of this document.

## The Nordson EFD Pledge

Thank You!

You have just purchased the world's finest precision dispensing equipment.

I want you to know that all of us at Nordson EFD value your business and will do everything in our power to make you a satisfied customer.

If at any time you are not fully satisfied with our equipment or the support provided by your Nordson EFD Product Application Specialist, please contact me personally at 800.556.3484 (US), 401.431.7000 (outside US), or [Tara.Tereso@nordsonefd.com](mailto:Tara.Tereso@nordsonefd.com).

I guarantee that we will resolve any problems to your satisfaction.

Thanks again for choosing Nordson EFD.



Tara Tereso, Vice President

# Contents

Contents .....	3
Introduction .....	4
Safety .....	4
Specifications .....	5
Installation .....	5
Unpack the System Components.....	5
Installation Example.....	6
Install the O-Ring .....	7
Install the Laser Light Barrier .....	8
Connect Cables .....	9
Overview of the Signal Amplifier Settings.....	9
Customize the Signal Amplifier Settings (Optional).....	10
Changing the Detection Sensitivity (Threshold) Setting .....	10
Changing the Pulse Time Delay (ms) Setting .....	10
Operation.....	11
Part Number .....	12
Replacement Parts .....	12
Laser Light Barrier Components.....	12
Laser Light Barrier Mounting Bracket.....	13
Nozzle Heaters.....	13
Heater Cables .....	13
Troubleshooting .....	14
Technical Data.....	15
Wiring Diagram .....	15
Signal Amplifier Cable (Output).....	15

## Introduction

The Laser Light Barrier monitors dispensing processes. The specially configured housing can be mounted easily on all Liquidyn® valves and can detect every dispensed material deposit.

Each material deposit, or shot, that passes through the light barrier triggers a 24V input / output (I/O) signal that is enhanced by a signal amplifier. This signal can be evaluated by a higher level controller.

The Laser Light Barrier can also detect contamination on its lens. If a possibility of lens contamination greater than 40% is detected, the system sends an alarm signal and the red alarm LED on the signal amplifier illuminates.

For ease of cleaning, no tools are required to install or uninstall the light barrier.

**NOTE:** To install the light barrier, either a standard nozzle heater or the Laser Light Barrier mounting bracket must be installed on the valve.



## Safety

- Operators are responsible for observing all safety instructions and for the intended use of this device.
- Operators are responsible for safely handling and using this device.
- Use only use fully functioning devices.

### Intended Use

The warranty is voided when:

- Damage occurs due to malfunction of the device caused by improper use or operation.
- The device was repaired or manipulated by persons who are neither authorized nor trained to do so.
- Damage is caused by the installation or use of accessories or spare parts not authorized by Nordson EFD.
- Electrical cables are damaged.
- An external impact has damaged the device.

# Specifications

**NOTE:** Specifications and technical details are subject to engineering change without prior notification.

Item	Specification
Operating voltage	24 VDC
Electrical power input	24 VDC, 40 mA maximum
Signal amplifier connector	M8, 3-pole
Maximum deposit detection rating	50Hz (50 shots per second)
Output signals for deposit and lens contamination detection	24 VDC PNP, 100 mA maximum

## Installation

Use this section in tandem with any other system component operating manuals to install all components of the system.

### Unpack the System Components

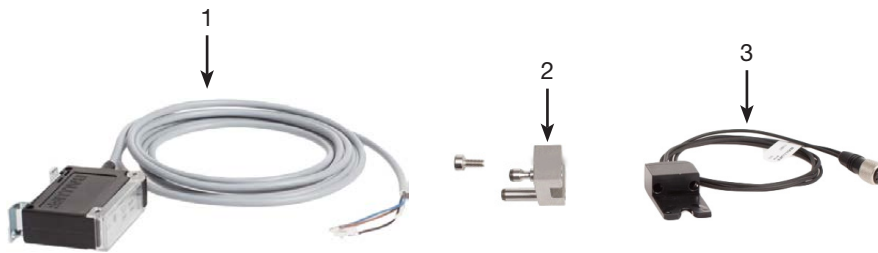

- 1 Signal amplifier
- 2 Spacer and M2.5 x 6 screw
- 3 Laser Light Barrier

# Installation (continued)

## Installation Example

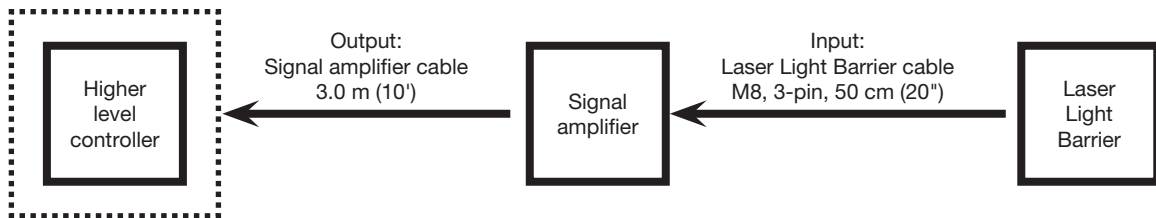
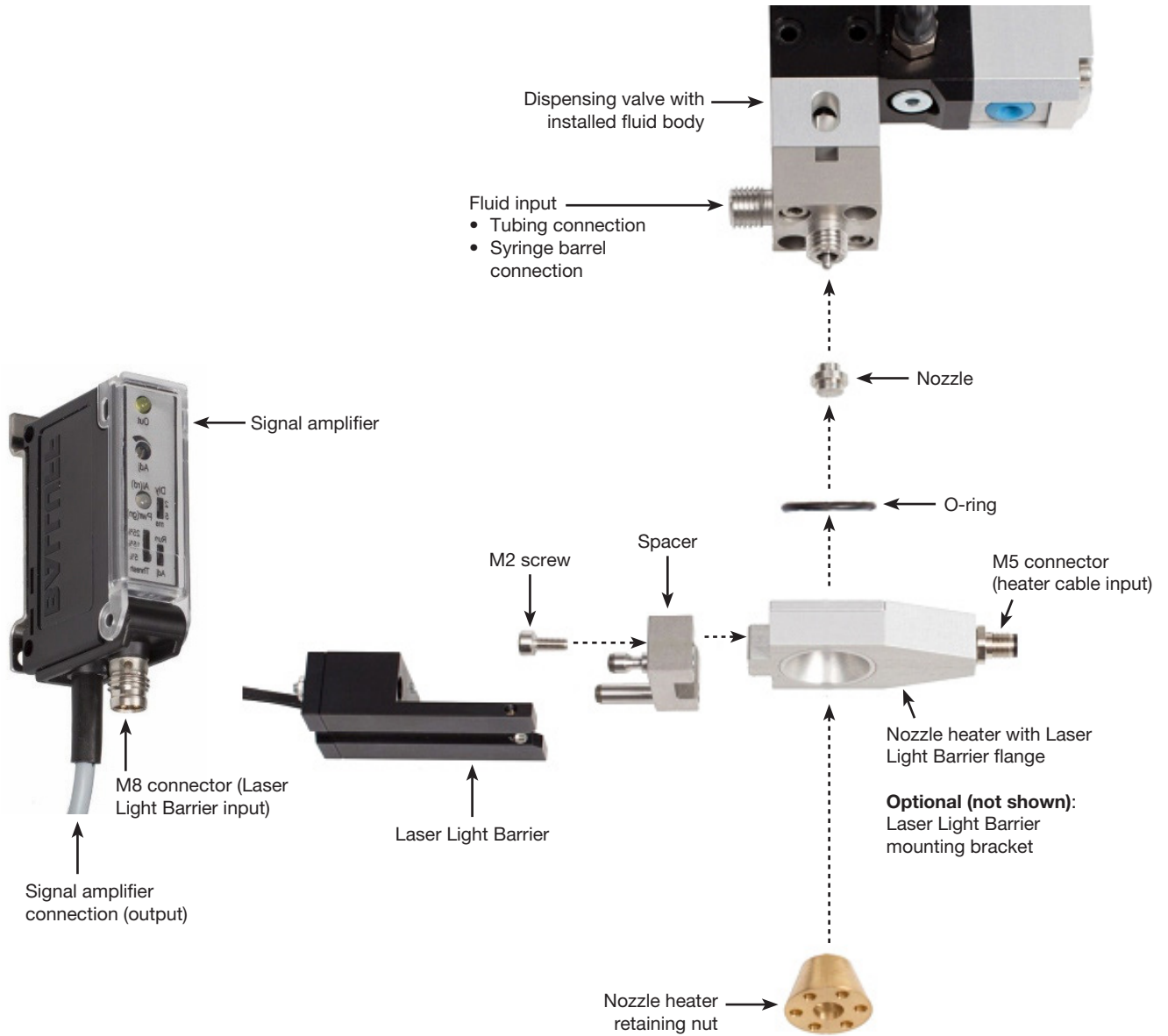

## Installation (continued)

### Install the O-Ring

#### NOTES:

- Refer to the valve operating manual for all installation and setup instructions for the valve.
  - For installations that do not require a nozzle heater, use the optional Laser Light Barrier mounting bracket instead.
1. Loosen the nozzle retaining nut and (if present) remove the nozzle heater.
  2. Remove the nozzle.

#### CAUTION

When the nozzle is removed, the fragile valve tappet protrudes from the fluid body. Take care not to damage the tappet by forcing or knocking it.

3. Place the O-ring in the groove on the nozzle heater (or mounting bracket).
4. Position the nozzle and nozzle heater (or mounting bracket) on the fluid body and use the heater key to secure these parts with the retaining nut.

#### NOTES:

- A nozzle heater can be installed in four different orientations.
- The nozzle retaining nut primarily fastens the nozzle in place. To ensure thermal contact, the nozzle heater (or mounting bracket) is pressed on to the retaining nut by an O-ring. This allows the nozzle heater (or mounting bracket) to remain movable while the tightened retaining nut keeps the nozzle sealed.

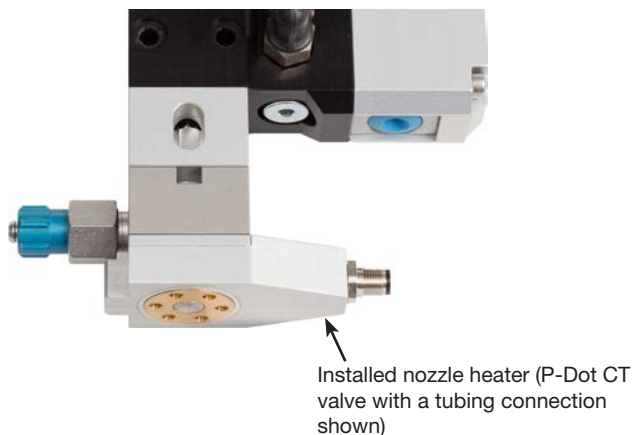
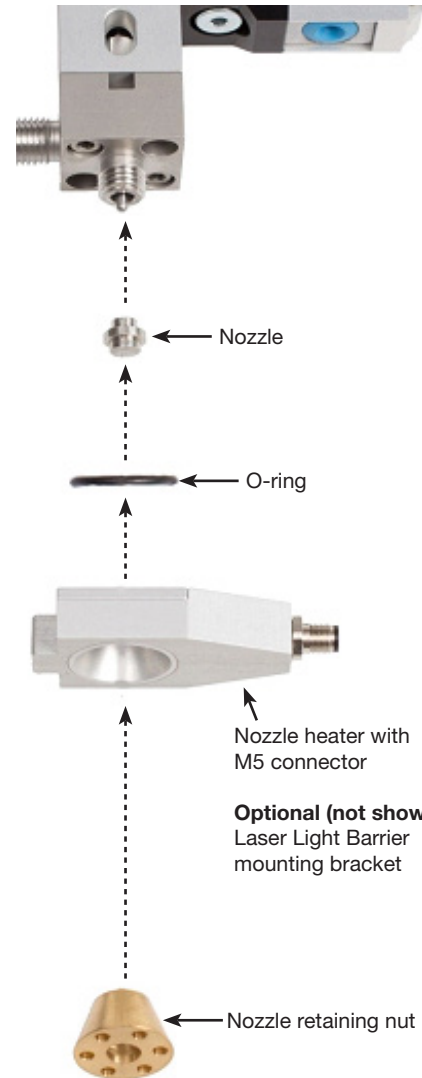

## Installation (continued)

### Install the Laser Light Barrier

**NOTE:** Illustrations that show spacer and light barrier installation options are provided below. These illustrations also show correct and incorrect light barrier-to-nozzle heater height settings.

1. Use the supplied M2 screw to mount the spacer in the desired orientation on the nozzle heater (or mounting bracket).

**NOTE:** To install the light barrier, the valve must include the standard nozzle heater or the Laser Light Barrier mounting bracket; additionally, the O-ring must be installed as shown under “Install the O-Ring” on page 7.

2. Adjust the height setting (the distance between the nozzle heater or mounting bracket and the light barrier) based on the nozzle type (flat or needle).
3. Attach the light barrier to the mounting pins on the spacer. No tools are required. The light barrier will click into place.

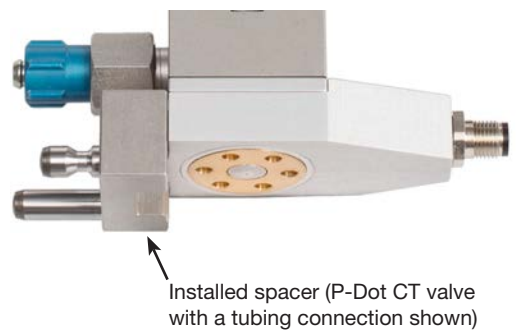
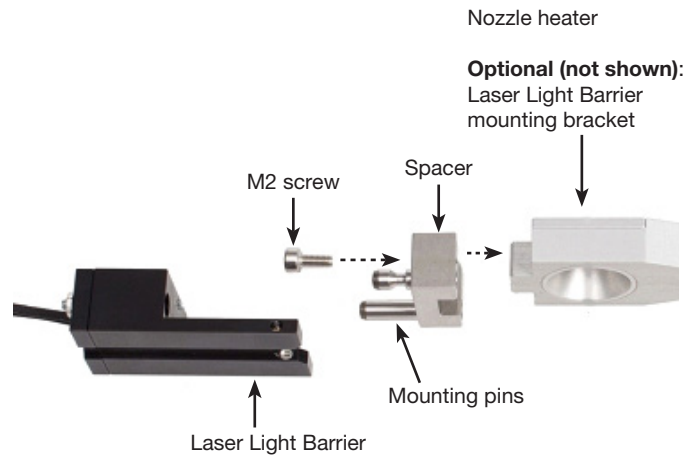

### Configuration options for the spacer depending on the nozzle type

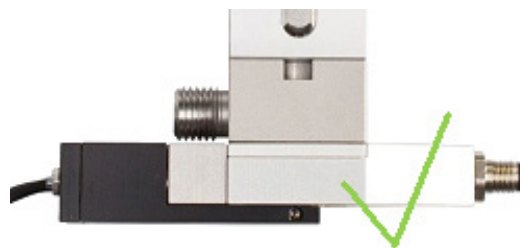
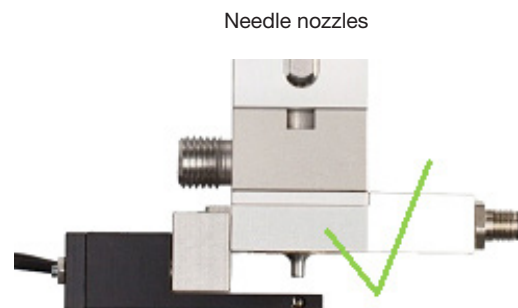
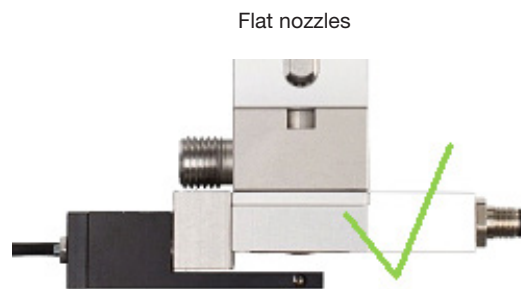



## Installation (continued)

### Connect Cables

1. Supply the dispensing valve with electricity and compressed air as described in the operating manual (compressed air tubing, valve cable, and nozzle heater cable).
2. Connect the Laser Light Barrier to the signal amplifier and supply the signal amplifier with the correct operating voltage.
3. Analyze the output of the signal amplifier with an oscilloscope or a PLC.

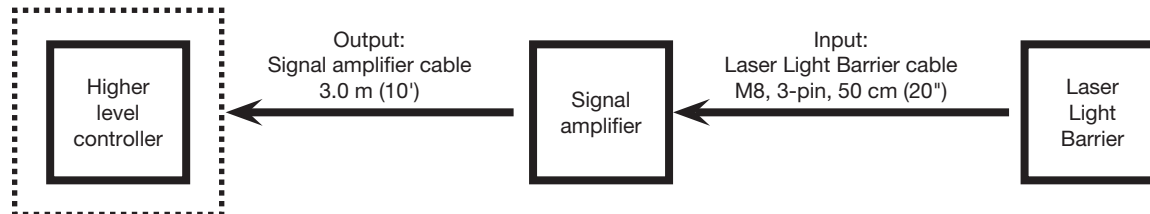

### Overview of the Signal Amplifier Settings

The signal amplifier is preset and can be put into operation with the default settings. If you need to adjust the settings, refer to “Customize the Signal Amplifier Settings (Optional)” on page 10.

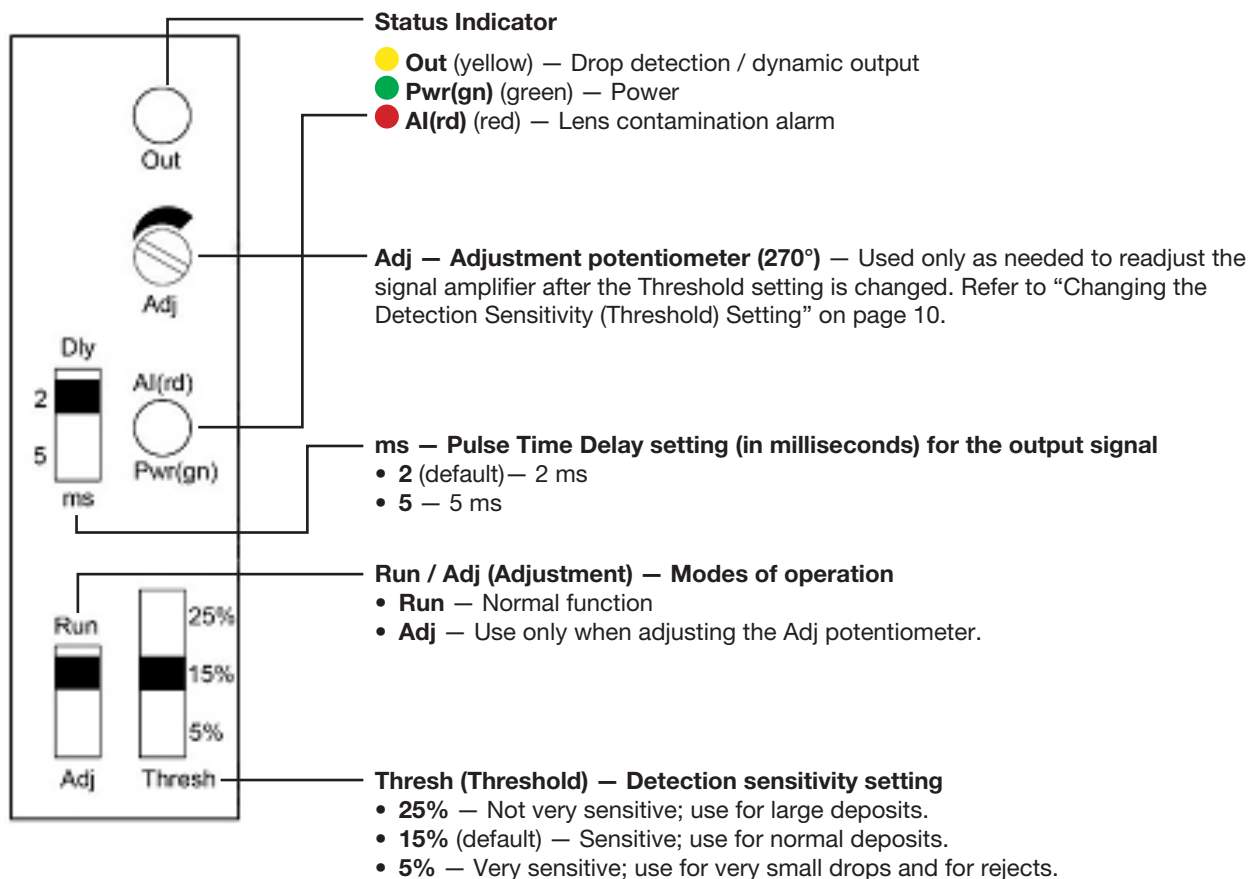

## Installation (continued)

### Customize the Signal Amplifier Settings (Optional)

If a positive result is not achieved with the default settings, you can change the following signal amplifier settings: Thresh and ms (Pulse Time Delay).

#### Changing the Detection Sensitivity (Threshold) Setting

##### **⚠ CAUTION**

Any time the Threshold setting is changed, the signal amplifier must be readjusted as described under “Adjusting the Signal Amplifier Setup after Threshold Change” below.

The detection sensitivity can be set to 5%, 15%, or 25%. The ideal setting depends on the dispensing frequency, the deposit diameter, and the dispensing material. If the default setting of 15% is not suitable, test the application using the other threshold setting options. Note that a higher sensitivity can cause a higher risk of failures.

#### Adjusting the Signal Amplifier Setup after Threshold Change

Readjust the signal amplifier after any change to the Thresh setting. This adjustment allows the light barrier to adapt to the production environment or the ambient light.

1. Move the Run / Adj switch to the Adj position.
2. Use an 0.4 x 0.2 mm screwdriver to turn the Adj potentiometer all the way to the left (until it stops and the Out LED illuminates red).
3. Turn the Adj potentiometer slowly to the right until the Out LED changes from red to green.
4. Move the Run / Adj switch back to the Run position.

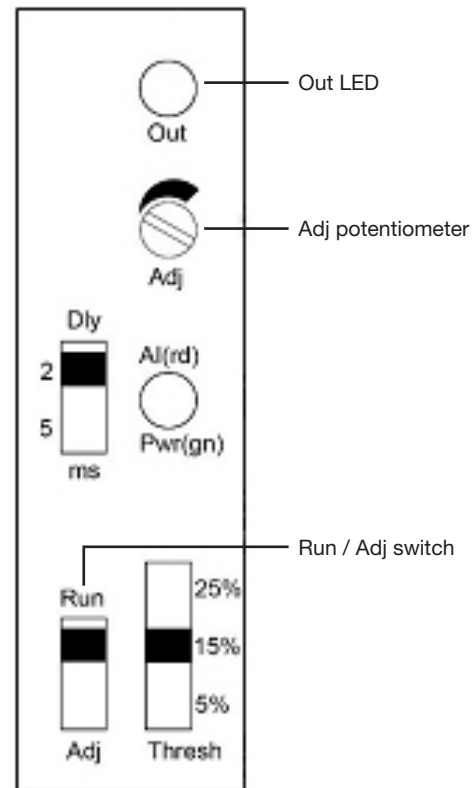

#### Changing the Pulse Time Delay (ms) Setting

The Pulse Time Delay setting allows you to provide more analysis time for PLCs with a long cycle time. The Pulse Time Delay extends the signal output time of the light barrier. It can be set to 2 or 5 ms (milliseconds).

## Operation

The Laser Light Barrier can be placed into operation immediately with the default signal amplifier settings. Every dispensed deposit that passes the light curtain sends an output signal through the signal amplifier for 2 or 5 ms, depending on the Pulse Time Delay (ms) setting. In addition, the Out LED illuminates yellow for every dispense cycle.

If the Laser Light Barrier fails to detect deposits, refer to “Troubleshooting” on page 14.

## Part Number

Part #	Description
7825237	Laser Light Barrier kit (includes the signal amplifier, light barrier, spacer, and M2 screw)



## Replacement Parts

### Laser Light Barrier Components

Part #	Description
7825236	Laser Light Barrier
7825238	Signal amplifier
7825239	Spacer



## Replacement Parts (continued)



### Laser Light Barrier Mounting Bracket

To use the Laser Light Barrier without a nozzle heater, this mounting bracket is required.

Part #	Description	
7825242	Laser Light Barrier mounting bracket	

### Nozzle Heaters

These nozzle heaters include a flange suitable for mounting the Laser Light Barrier. Refer to “Heater Cables” for suitable cables.

Part #	Description	
7825149	Nozzle heater kit, standard, M5, straight plug	The kit includes the heater element, retaining nut, plug, O-ring, and heater key.
7825150	Nozzle heater kit, standard, M5, 90-degree plug	
7825148	Nozzle heater element, standard, M5	
7825152	Nozzle heater element, standard, M8	
7825157	Nozzle heater element, large, M5 <b>NOTE:</b> This larger heater element heats the material farther up into the supply tubing, allowing more fluid to be heated before it is dispensed.	

### Heater Cables

Part #	Description	
7825182	2.5 m (8.2 ft) M8 valve cable	
7825183	0.5 m (1.6 ft) M8 valve cable	
7825176	3 m (10 ft) M5 valve cable, straight plug	
7825177	3 m (10 ft) M5 valve cable, 90-degree plug	

## Troubleshooting

Problem	Possible Cause	Corrective Action
Dispensing cycles not detected (Out LED does not illuminate yellow) when the signal amplifier is using the default settings	Deposits not detaching from dispensing valve	Check the valve. Refer to the valve operating manual.
	Signal amplifier settings not correct for the application	Customize the signal amplifier settings. Refer to “Customize the Signal Amplifier Settings (Optional)” on page 10.
Out LED does not illuminate yellow when the signal amplifier settings have been customized	Light barrier not properly aligned with the nozzle axis	Refer to “Light Barrier Axis Alignment” below to correct the alignment.

### Light Barrier Axis Alignment

The axis of the light barrier is factory-aligned to the nozzle axis. If the system cannot detect dispensing cycles despite customized signal amplifier settings, follow this procedure to realign the light barrier and nozzle axes.

1. Disconnect the signal amplifier cable from the light barrier.
2. Use a 4-mm open-end wrench to loosen the jam nut that secures the set screw.
3. Align the light barrier axis to the nozzle axis by using a hex wrench to adjust the set screw (M2 x 10).  
**NOTE:** The distance between the light barrier and spacer can be 0–0.5 mm (0–0.02”).
4. Use the hex wrench to hold the set screw in the new position and then tighten the jam nut.
5. Reconnect the signal amplifier cable and test the result. Every deposit that passes the light barrier should cause the Out LED on the signal amplifier to illuminate yellow.

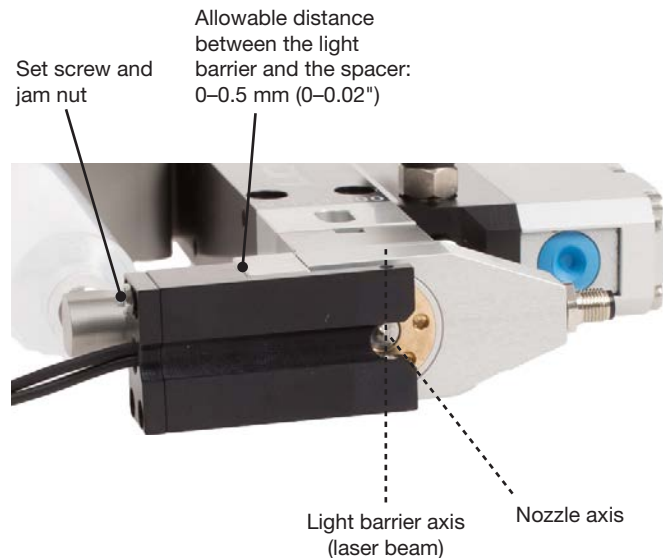



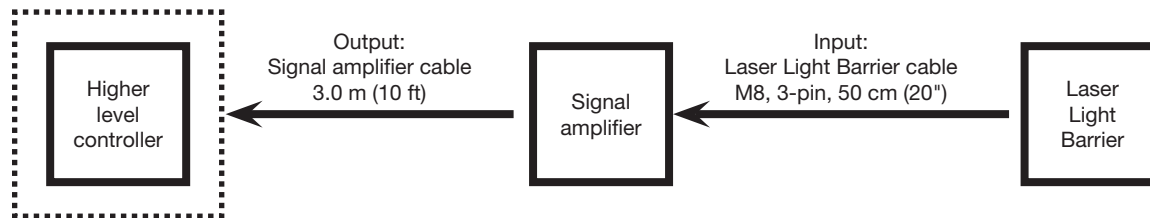

## Technical Data

### Wiring Diagram



### Signal Amplifier Cable (Output)

Wire Color		Description
	Brown	Operating voltage +24 VDC (min. +10 VDC, max. +30 VDC)
	Blue	Earth 0V, normally closed
	Black	Output for drop detection / dynamic output: 24 VDC, max. 200 mA, PNP
	White	Output for lens contamination alarm: 24 VDC, max. 200mA, PNP

## NORDSON EFD ONE YEAR LIMITED WARRANTY

This Nordson EFD product is warranted for one year from the date of purchase to be free from defects in material and workmanship (but not against damage caused by misuse, abrasion, corrosion, negligence, accident, faulty installation, or by dispensing material incompatible with equipment) when the equipment is installed and operated in accordance with factory recommendations and instructions.

Nordson EFD will repair or replace free of charge any defective part upon authorized return of the part prepaid to our factory during the warranty period. The only exceptions are those parts which normally wear and must be replaced routinely, such as, but not limited to, valve diaphragms, seals, valve heads, needles, and nozzles.

In no event shall any liability or obligation of Nordson EFD arising from this warranty exceed the purchase price of the equipment.

Before operation, the user shall determine the suitability of this product for its intended use, and the user assumes all risk and liability whatsoever in connection therewith. Nordson EFD makes no warranty of merchantability or fitness for a particular purpose. In no event shall Nordson EFD be liable for incidental or consequential damages.

This warranty is valid only when oil-free, clean, dry, filtered air is used, where applicable.



For Nordson EFD sales and service in over 40 countries, contact Nordson EFD or go to [www.nordsonefd.com](http://www.nordsonefd.com).

**Global**

800-556-3484; +1-401-431-7000  
[info@nordsonefd.com](mailto:info@nordsonefd.com)

**Europe**

00800 7001 7001  
[infoefd.europe@nordsonefd.com](mailto:infoefd.europe@nordsonefd.com)

**Asia**

China: +86 (21) 3866 9006; [china@nordsonefd.com](mailto:china@nordsonefd.com)  
India: +91 80 4021 3600; [india@nordsonefd.com](mailto:india@nordsonefd.com)  
Japan: +81 03 5762 2760; [japan@nordsonefd.com](mailto:japan@nordsonefd.com)  
Korea: +82-31-736-8321; [korea@nordsonefd.com](mailto:korea@nordsonefd.com)  
SEAsia: +65 6796 9522; [sin-mal@nordsonefd.com](mailto:sin-mal@nordsonefd.com)

The Wave Design is a trademark of Nordson Corporation.  
©2021 Nordson Corporation 7363237 v012121