

You have selected a reliable, high-quality dispensing system component from Nordson EFD, the world leader in fluid dispensing. The ProcessMate™ TC100 Temperature Controller and barrel heater assembly are designed specifically for industrial dispensing and will provide you with years of trouble-free, productive service.

This manual will help you maximize the usefulness of your ProcessMate TC100 Temperature Controller and barrel heater assembly.

Please spend a few minutes to become familiar with the controls and features. Follow our recommended testing procedures. Review the helpful information we have included, which is based on more than 50 years of industrial dispensing experience.

Most questions you will have are answered in this manual. However, if you need assistance, please do not hesitate to contact EFD or your authorized EFD distributor. Detailed contact information is provided on the last page of this document.

The Nordson EFD Pledge

Thank You!

You have just purchased the world's finest precision dispensing equipment.

I want you to know that all of us at Nordson EFD value your business and will do everything in our power to make you a satisfied customer.

If at any time you are not fully satisfied with our equipment or the support provided by your Nordson EFD Product Application Specialist, please contact me personally at 800.556.3484 (US), 401.431.7000 (outside US), or Tara.Tereso@nordsonefd.com.

I guarantee that we will resolve any problems to your satisfaction.

Thanks again for choosing Nordson EFD.

A stylized, handwritten signature of Tara Tereso in black ink.

Tara Tereso, Vice President

Contents

Contents	3
Introduction	4
Nordson EFD Product Safety Statement	5
Halogenated Hydrocarbon Solvent Hazards	6
High Pressure Fluids	6
Qualified Personnel	6
Intended Use	7
Regulations and Approvals	7
Personal Safety	7
Fire Safety	8
Preventive Maintenance	8
Important Disposable Component Safety Information	9
Action in the Event of a Malfunction	9
Disposal	9
Equipment-Specific Safety Information	9
Specifications	10
ProcessMate TC100 Temperature Controller	10
Barrel Heater Assembly	10
Operating Features	11
ProcessMate TC100 Temperature Controller	11
Barrel Heater Assembly	12
Installation	13
Unpack the System Components	13
Install the Barrel Heater Assembly and Unity HiTemp Syringe Barrel	14
Install the ProcessMate TC100 Controller	15
Typical Automated Dispensing System Installation	16
Setup	17
Operation	18
Startup	18
Shutdown	18
Part Numbers	19
ProcessMate TC100 Temperature Controller and Barrel Heater	19
Unity HiTemp Syringe Barrels	19
Neoprene Piston	19
Replacement Parts	19
Troubleshooting	19

Introduction

This manual provides safety, installation, operation, service, and parts information for the ProcessMate TC100 Temperature Controller and the syringe barrel heater assembly.

The barrel heater sleeve wraps around a Nordson EFD Unity™ HiTemp™ syringe barrel to heat the fluid supply. The barrel heater assembly can be used for a Unity HiTemp syringe barrel installed on any automated dispensing system robot, or for a barrel mounted on a stand or similar device.

The ProcessMate TC100 Temperature Controller provides precise temperature control and monitoring for the barrel heater assembly.

The system integrates seamlessly with Nordson EFD fluid dispensers, which actuate the dispense cycle.

Intended Use

- The TC100 barrel heater is specially designed for Unity HiTemp syringe barrels. Use only Unity HiTemp syringe barrels with the ProcessMate TC100 system.
- Use only neoprene pistons.
- Use only high-temperature tips caps to seal syringe barrels for filling.

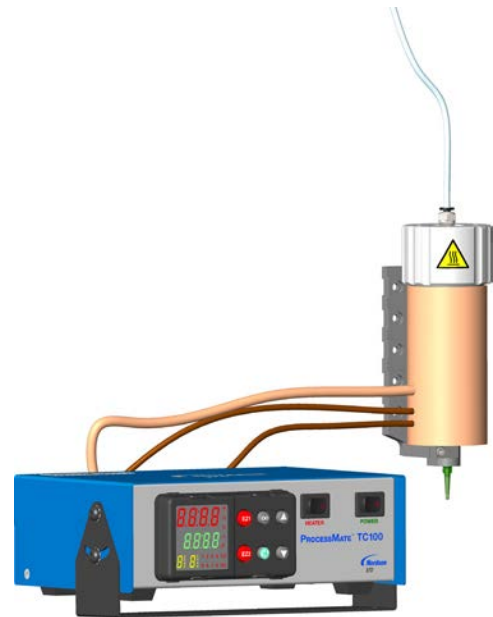

Nordson EFD Product Safety Statement

WARNING

The safety message that follows has a WARNING level hazard.
Failure to comply could result in death or serious injury.



ELECTRIC SHOCK

Risk of electric shock. Disconnect power before removing covers and / or disconnect, lock out, and tag switches before servicing electrical equipment. If you receive even a slight electrical shock, shut down all equipment immediately. Do not restart the equipment until the problem has been identified and corrected.

CAUTION

The safety messages that follow have a CAUTION level hazard.
Failure to comply may result in minor or moderate injury.



READ MANUAL

Read manual for proper use of this equipment. Follow all safety instructions. Task- and equipment-specific warnings, cautions, and instructions are included in equipment documentation where appropriate. Make sure these instructions and all other equipment documents are accessible to persons operating or servicing equipment.



MAXIMUM AIR PRESSURE

Unless otherwise noted in the product manual, the maximum air input pressure is 7.0 bar (100 psi). Excessive air input pressure may damage the equipment. Air input pressure is intended to be applied through an external air pressure regulator rated for 0 to 7.0 bar (0 to 100 psi).



RELEASE PRESSURE

Release hydraulic and pneumatic pressure before opening, adjusting, or servicing pressurized systems or components.



BURNS

Hot surfaces! Avoid contact with the hot metal surfaces of heated components. If contact can not be avoided, wear heat-protective gloves and clothing when working around heated equipment. Failure to avoid contact with hot metal surfaces can result in personal injury.

Nordson EFD Product Safety Statement (continued)

Halogenated Hydrocarbon Solvent Hazards

Do not use halogenated hydrocarbon solvents in a pressurized system that contains aluminum components. Under pressure, these solvents can react with aluminum and explode, causing injury, death, or property damage. Halogenated hydrocarbon solvents contain one or more of the following elements.

Element	Symbol	Prefix
Fluorine	F	“Fluoro-”
Chlorine	Cl	“Chloro-”
Bromine	Br	“Bromo-”
Iodine	I	“Iodo-”

Check the Safety Data Sheet (SDS) or contact your material supplier for more information. If you must use halogenated hydrocarbon solvents, contact your EFD representative for compatible EFD components.

High Pressure Fluids

High pressure fluids, unless they are safely contained, are extremely hazardous. Always release fluid pressure before adjusting or servicing high pressure equipment. A jet of high pressure fluid can cut like a knife and cause serious bodily injury, amputation, or death. Fluids penetrating the skin can also cause toxic poisoning.

WARNING

Any injury caused by high pressure liquid can be serious. If you are injured or even suspect an injury:

- Go to an emergency room immediately.
- Tell the doctor that you suspect an injection injury.
- Show the doctor the following note.
- Tell the doctor what kind of material you were dispensing.

Medical Alert — Airless Spray Wounds: Note to Physician

Injection in the skin is a serious traumatic injury. It is important to treat the injury surgically as soon as possible. Do not delay treatment to research toxicity. Toxicity is a concern with some exotic coatings injected directly into the bloodstream.

Qualified Personnel

Equipment owners are responsible for making sure that EFD equipment is installed, operated, and serviced by qualified personnel. Qualified personnel are those employees or contractors who are trained to safely perform their assigned tasks. They are familiar with all relevant safety rules and regulations and are physically capable of performing their assigned tasks.

Nordson EFD Product Safety Statement (continued)

Intended Use

Use of EFD equipment in ways other than those described in the documentation supplied with the equipment may result in injury to persons or damage to property. Some examples of unintended use of equipment include:

- Using incompatible materials.
- Making unauthorized modifications.
- Removing or bypassing safety guards or interlocks.
- Using incompatible or damaged parts.
- Using unapproved auxiliary equipment.
- Operating equipment in excess of maximum ratings.
- Operating equipment in an explosive atmosphere.

Regulations and Approvals

Make sure all equipment is rated and approved for the environment in which it is used. Any approvals obtained for Nordson EFD equipment will be voided if instructions for installation, operation, and service are not followed. If the equipment is used in a manner not specified by Nordson EFD, the protection provided by the equipment may be impaired.

Personal Safety

To prevent injury, follow these instructions:

- Do not operate or service equipment unless you are qualified.
- Do not operate equipment unless safety guards, doors, and covers are intact and automatic interlocks are operating properly. Do not bypass or disarm any safety devices.
- Keep clear of moving equipment. Before adjusting or servicing moving equipment, shut off the power supply and wait until the equipment comes to a complete stop. Lock out power and secure the equipment to prevent unexpected movement.
- Make sure spray areas and other work areas are adequately ventilated.
- When using a syringe barrel, always keep the dispensing end of the tip pointing towards the work and away from the body or face. Store syringe barrels with the tip pointing down when they are not in use.
- Obtain and read the Safety Data Sheet (SDS) for all materials used. Follow the manufacturer's instructions for safe handling and use of materials and use recommended personal protection devices.
- Be aware of less-obvious dangers in the workplace that often cannot be completely eliminated, such as hot surfaces, sharp edges, energized electrical circuits, and moving parts that cannot be enclosed or otherwise guarded for practical reasons.
- Know where emergency stop buttons, shutoff valves, and fire extinguishers are located.
- Wear hearing protection to protect against hearing loss that can be caused by exposure to vacuum exhaust port noise over long periods of time.

Nordson EFD Product Safety Statement (continued)

Fire Safety

To prevent a fire or explosion, follow these instructions:

- Shut down all equipment immediately if you notice static sparking or arcing. Do not restart the equipment until the cause has been identified and corrected.
- Do not smoke, weld, grind, or use open flames where flammable materials are being used or stored.
- Do not heat materials to temperatures above those recommended by the manufacturer. Make sure heat monitoring and limiting devices are working properly.
- Provide adequate ventilation to prevent dangerous concentrations of volatile particles or vapors. Refer to local codes or the SDS for guidance.
- Do not disconnect live electrical circuits when working with flammable materials. Shut off power at a disconnect switch first to prevent sparking.
- Know where emergency stop buttons, shutoff valves, and fire extinguishers are located.

Preventive Maintenance

As part of maintaining continuous trouble-free use of this product, Nordson EFD recommends the following simple preventive maintenance checks:

- Periodically inspect tube-to-fitting connections for proper fit. Secure as necessary.
- Check tubing for cracks and contamination. Replace tubing as necessary.
- Check all wiring connections for looseness. Tighten as necessary.
- Clean: If a front panel requires cleaning, use a clean, soft, damp rag with a mild detergent cleaner. DO NOT USE strong solvents (MEK, acetone, THF, etc.) as they will damage the front panel material.
- Maintain: Use only a clean, dry air supply to the unit. The equipment does not require any other regular maintenance.
- Test: Verify the operation of features and the performance of equipment using the appropriate sections of this manual. Return faulty or defective units to Nordson EFD for replacement.
- Use only replacement parts that are designed for use with the original equipment. Contact your Nordson EFD representative for information and advice.

Nordson EFD Product Safety Statement (continued)

Important Disposable Component Safety Information

All Nordson EFD disposable components, including syringe barrels, cartridges, pistons, tip caps, end caps, and dispense tips, are precision engineered for one-time use. Attempting to clean and re-use components will compromise dispensing accuracy and may increase the risk of personal injury.

Always wear appropriate protective equipment and clothing suitable for your dispensing application and adhere to the following guidelines:

- Do not heat syringe barrels or cartridges to a temperature greater than 38° C (100° F).
- Dispose of components according to local regulations after one-time use.
- Do not clean components with strong solvents (MEK, acetone, THF, etc.).
- Clean cartridge retainer systems and barrel loaders with mild detergents only.
- To prevent fluid waste, use Nordson EFD SmoothFlow™ pistons.

Action in the Event of a Malfunction

If a system or any equipment in a system malfunctions, shut off the system immediately and perform the following steps:

1. Disconnect and lock out system electrical power. If using hydraulic and pneumatic shutoff valves, close and relieve pressure.
2. For Nordson EFD air-powered dispensers, remove the syringe barrel from the adapter assembly. For Nordson EFD electro-mechanical dispensers, slowly unscrew the barrel retainer and remove the barrel from the actuator.
3. Identify the reason for the malfunction and correct it before restarting the system.

Disposal

Dispose of equipment and materials used in operation and servicing according to local codes.

Equipment-Specific Safety Information

The following safety information is specific to the ProcessMate TC100 Temperature Controller and barrel heater assembly.

WARNING

Risk of personal injury or equipment damage. Use only Unity HiTemp components with the ProcessMate TC100 system. Using any other barrels or components can damage components, causing leakage of hot material.

CAUTION

Risk of equipment damage. Use only neoprene pistons with the ProcessMate TC100 system. Use of other pistons can cause poor dispensing results.

The following statements on this page of the “Nordson EFD Product Safety Statement” do NOT apply to the ProcessMate TC100 system:

- Do not heat syringe barrels or cartridges to a temperature greater than 38° C (100° F).
- To prevent fluid waste, use Nordson EFD SmoothFlow pistons.

Specifications

NOTE: Specifications and technical details are subject to change without prior notification.

ProcessMate TC100 Temperature Controller

Item	Specification
Cabinet size	21.5W × 8.4H × 15.7D cm (8.46W × 3.30H × 6.18D")
Weight	1.3 kg (2.9 lb)
Input AC (to power supply)	100–240 VAC, ±10%, 50/60Hz, 20 Amp maximum
Output DC (from power supply)	24 VDC, 2 Amp maximum
Temperature control*	20–100° C (68–212° F)
Temperature accuracy	±1.0° C (±1.8° F)
Ambient operating temperature	Temperature: 0–40° C (32–104° F) Humidity: 10–80% Storage temperature: 10–60° C (50–140° F)
Approvals	CE, TÜV, RoHS, China RoHS, WEEE

*Because the unit does not cool, it cannot achieve a temperature setpoint that is below the ambient temperature.

Barrel Heater Assembly

Item	Specification
Size	57.2W x 157.0H x 71.3D mm (2.25W x 6.18H x 2.81D") (with mounting bracket, without dispensing tip)
Weight	Syringe barrel retainer: 0.4 kg (0.8 lb) Heater sleeve: 0.3 kg (0.6 lb)
Retainer cap	Acetal
Syringe barrel retainer	Anodized aluminum
Luer clamp	Anodized aluminum

RoHS标准相关声明 (China RoHS Hazardous Material Declaration)

产品名称 Part Name	有害物质及元素 Toxic or Hazardous Substances and Elements					
	铅 Lead (Pb)	汞 Mercury (Hg)	镉 Cadmium (Cd)	六价铬 Hexavalent Chromium (Cr6)	多溴联苯 Polybrominated Biphenyls (PBB)	多溴联苯醚 Polybrominated Diphenyl Ethers (PBDE)
外部接口 External Electrical Connectors	X	0	0	0	0	0
<p>0: 表示该产品所含有的危险成分或有害物质含量依照EIP-A, EIP-B, EIP-C 的标准低于SJ/T11363-2006 限定要求。 Indicates that this toxic or hazardous substance contained in all the homogeneous materials for this part, according to EIP-A, EIP-B, EIP-C is below the limit requirement in SJ/T11363-2006.</p> <p>X: 表示该产品所含有的危险成分或有害物质含量依照EIP-A, EIP-B, EIP-C 的标准高于SJ/T11363-2006 限定要求。 Indicates that this toxic or hazardous substance contained in all the homogeneous materials for this part, according to EIP-A, EIP-B, EIP-C is above the limit requirement in SJ/T11363-2006.</p>						

WEEE Directive



This equipment is regulated by the European Union under WEEE Directive (2012/19/EU). Refer to www.nordsonefd.com/WEEE for information about how to properly dispose of this equipment.

Operating Features

ProcessMate TC100 Temperature Controller

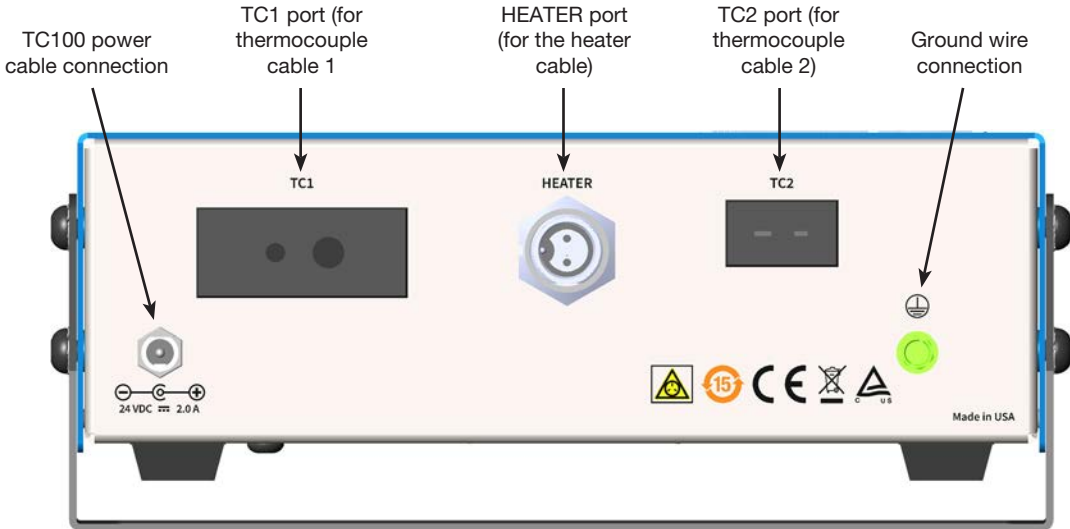
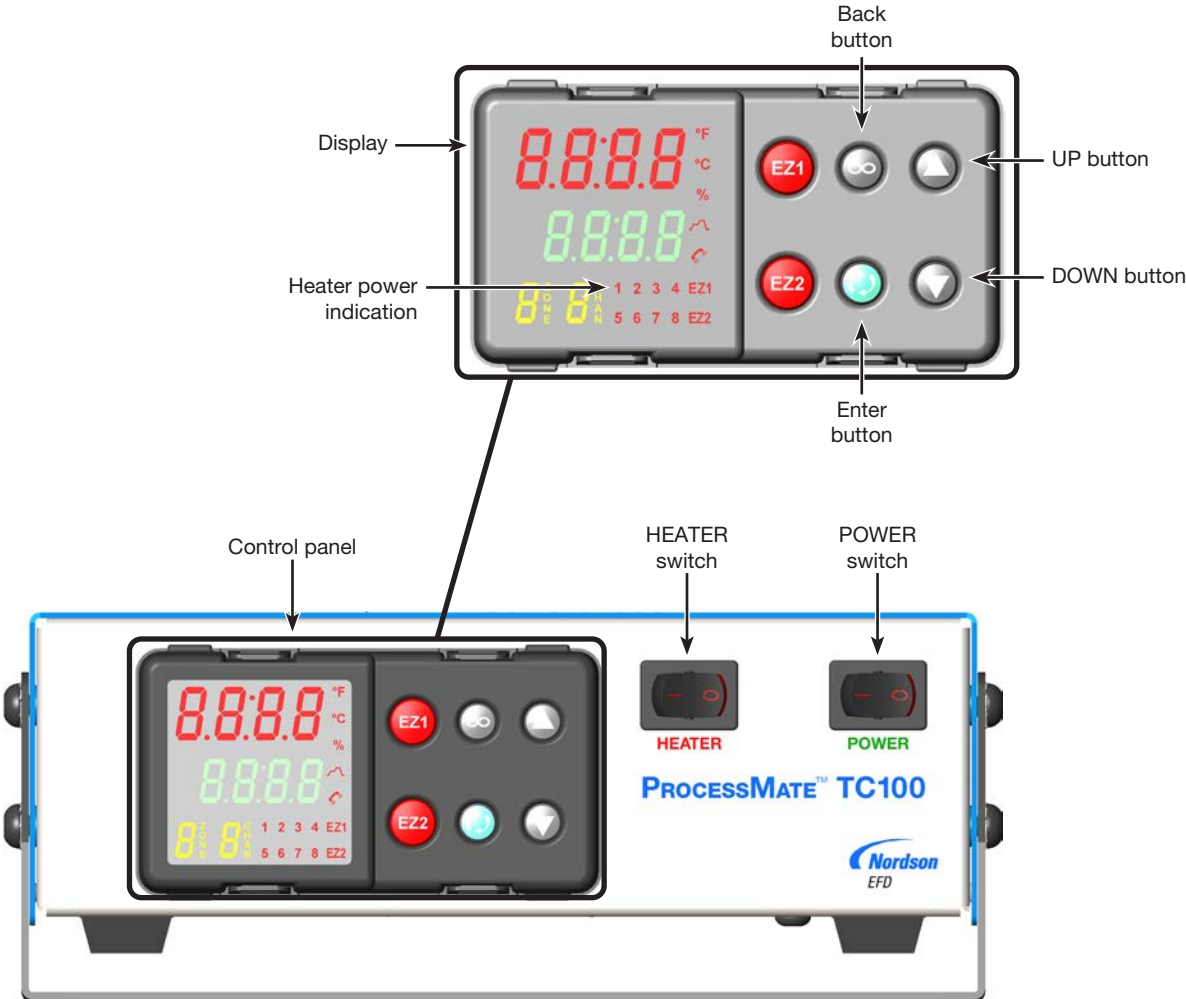

Operating Features (continued)

Barrel Heater Assembly

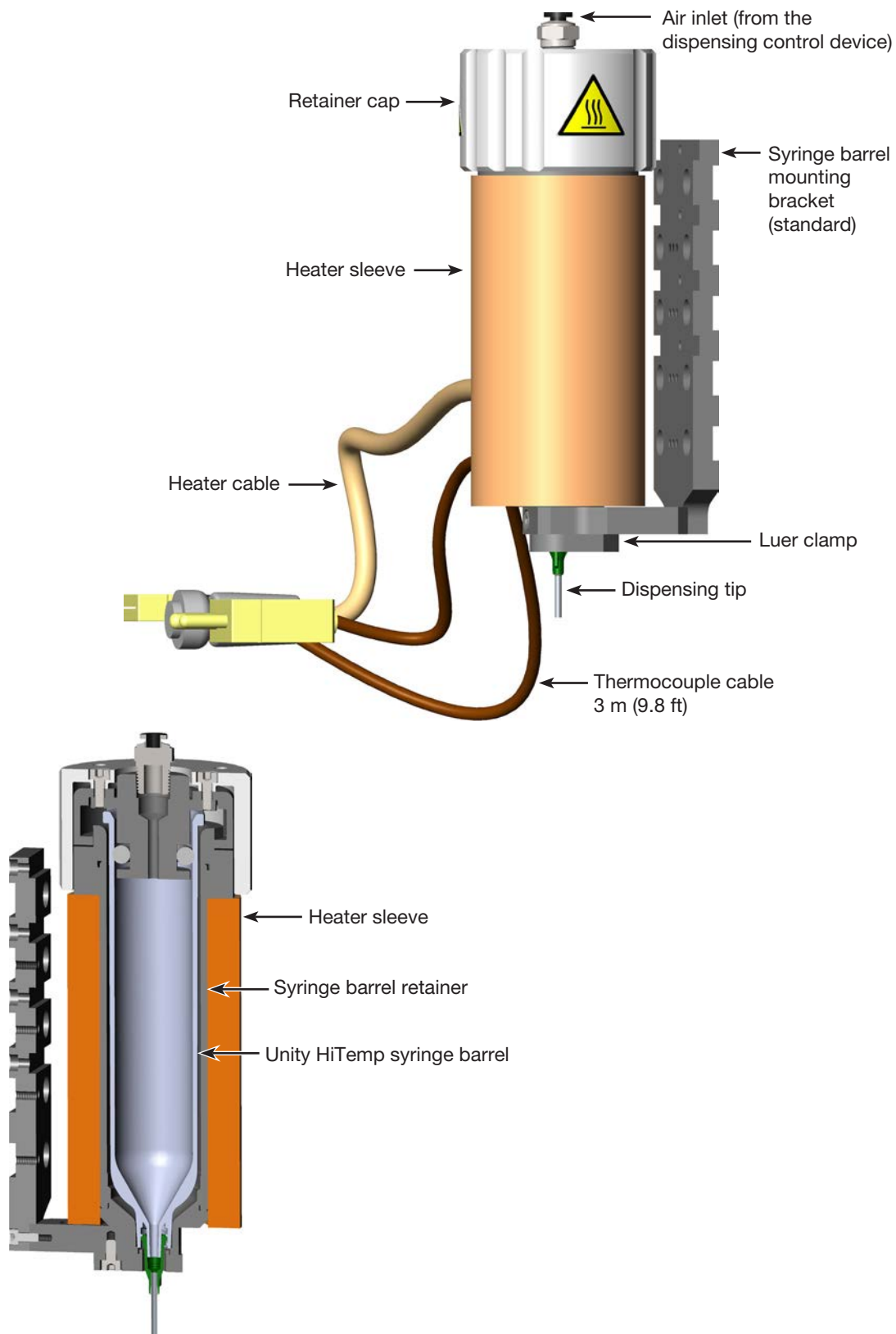

Installation

Use this section in tandem with any other system component operating manuals to install all components of the system.

Unpack the System Components

Inspect all components for any damage or missing pieces. Contact your Nordson EFD representative if any components are damaged.



- 1 ProcessMate TC100 controller
- 2 Power cord and power supply
- 3 High temperature tubing, 1.8 m (6 ft)
- 4 Barrel heater assembly components

(Not shown)

- 5 Neoprene pistons (pack of 20)
- 6 Unity HiTemp syringe barrels (pack of 20)

NOTE: For all Unity HiTemp part numbers, refer to the Unity HiTemp data sheet:

www.nordsonefd.com/UnityHiTempBarrels

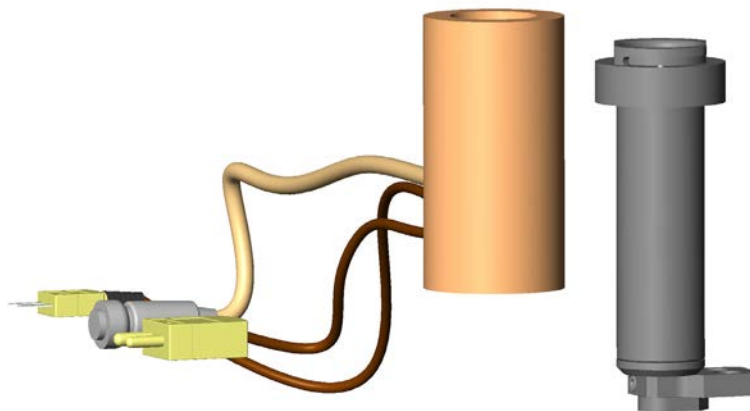

Installation (continued)

WARNING

Use only Unity HiTemp syringe barrels with the ProcessMate TC100 system. The barrel heater is specially designed for Unity HiTemp syringe barrels. Using any other barrel will damage the barrel and can cause leakage.

Install the Barrel Heater Assembly and Unity HiTemp Syringe Barrel

Refer to “Install the ProcessMate TC100 Controller” on page 15 for a system layout image.

Install the Heater Sleeve and Mount the Bracket

1. Secure the heater sleeve around the syringe barrel retainer.
2. Mount the syringe barrel retainer on the robot bracket (a typical bracket is shown) or on a stand, as applicable for your installation.

Prepare the Syringe Barrel

3. Fill the Unity HiTemp syringe barrel with your material.
4. If using a piston (not shown), insert a neoprene piston in the syringe barrel.
5. Install the retainer cap on the syringe barrel, turning the cap clockwise until it locks into place.
6. Install the dispensing tip on the syringe barrel.

Insert the Syringe Barrel into the Retainer

7. Loosen the set screw that secures the luer clamp at the base of the syringe barrel retainer.
8. Slide the retainer cap / syringe barrel / tip assembly into the retainer.

NOTE: If there are several labels on the barrel, they may need to be removed to ensure a good fit in the retainer.
9. Tighten the luer clamp set screw.

Make the Remaining System Connections

10. Insert the high-temperature air supply tubing from the air output of the dispenser (or other device that will be used to control dispensing) into the push-in air fitting on the top of the retainer cap.
11. Make all additional material and air supply tubing connections, ensuring that tubing is long enough to accommodate robot movement with slack.
12. Continue to the next procedure to install the TC100 controller and to make the power, heater, and thermocouple cable connections.

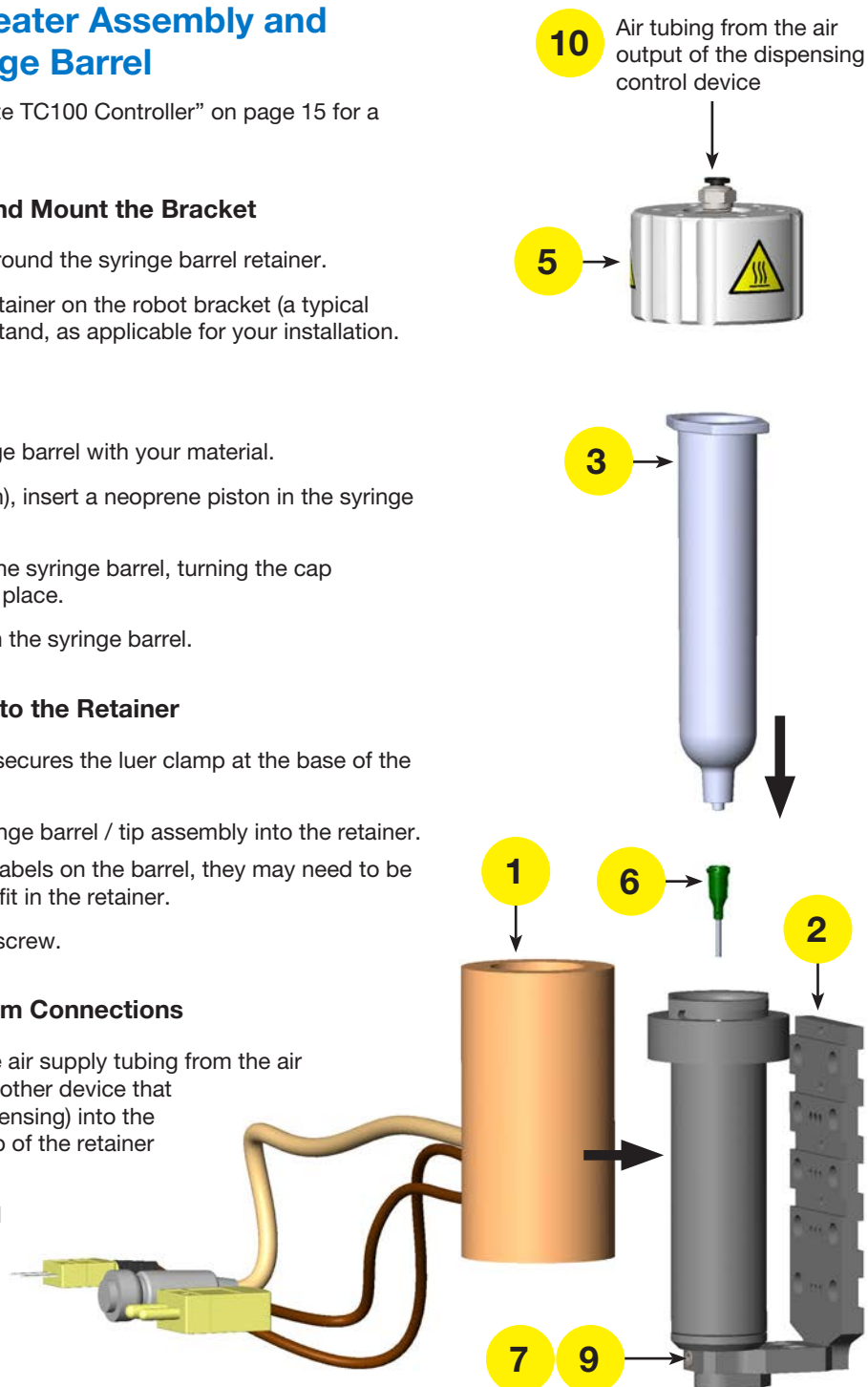

Installation (continued)

Install the ProcessMate TC100 Controller

Refer to “Typical Automated Dispensing System Installation” on page 16 for a typical installation onto a robot.

CAUTION

Before installation, switch OFF both the controller power and the heater power. The heater setpoint should be correctly set before switching on the heater power.

1. On the front of the controller, ensure that the POWER and HEATER switches are in the OFF position.
2. Connect the power supply cable to the power input on the back of the controller and to your local power source.
3. Connect a ground wire.
 - a. Connect a 16 AWG (1.3 mm) ground wire to the chassis grounding screw on the rear of the chassis using a toothed grounding lug. The wire must have green insulation with a yellow stripe or must be non-insulated (bare).
 - b. Attach the opposite end of the ground wire to a permanent earth ground using toothed washers or a toothed lug.
4. Connect the two thermocouple cables to TC1 and TC2 on the back of the controller.
5. Connect the barrel heater cable to HEATER on the back of the controller.

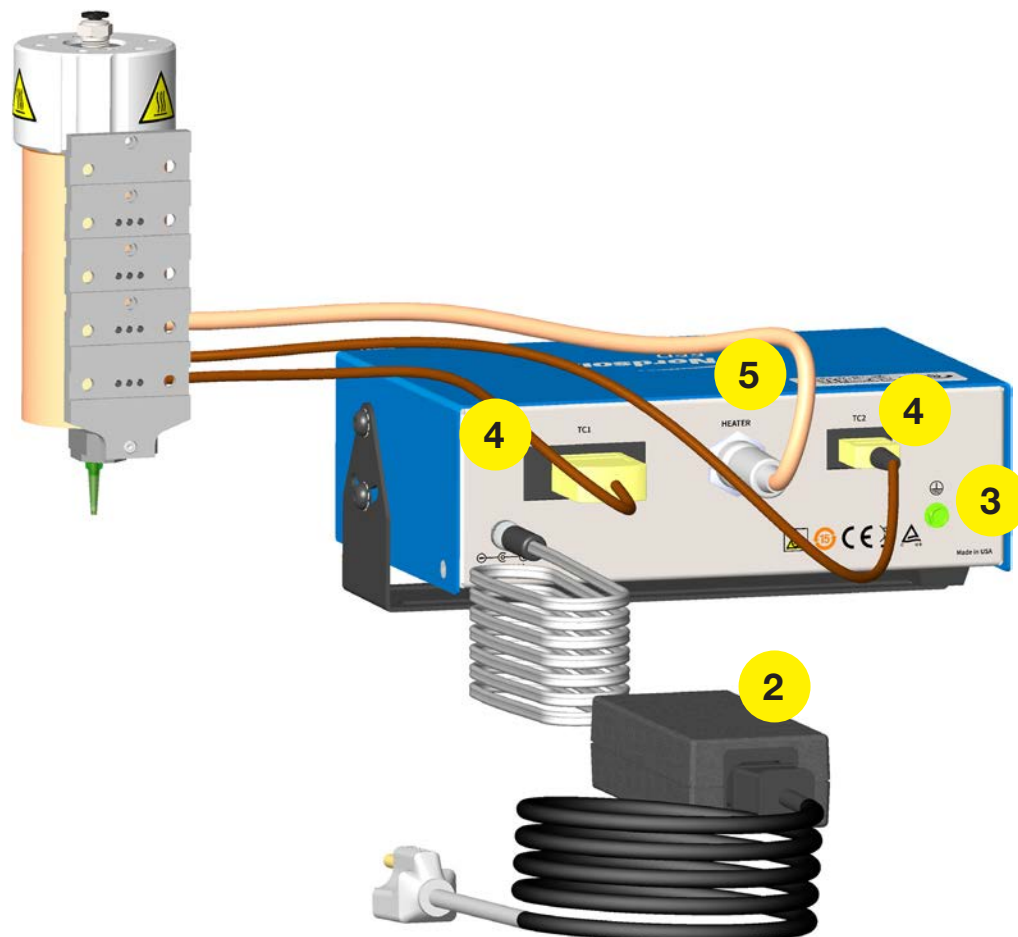

Installation (continued)

Typical Automated Dispensing System Installation

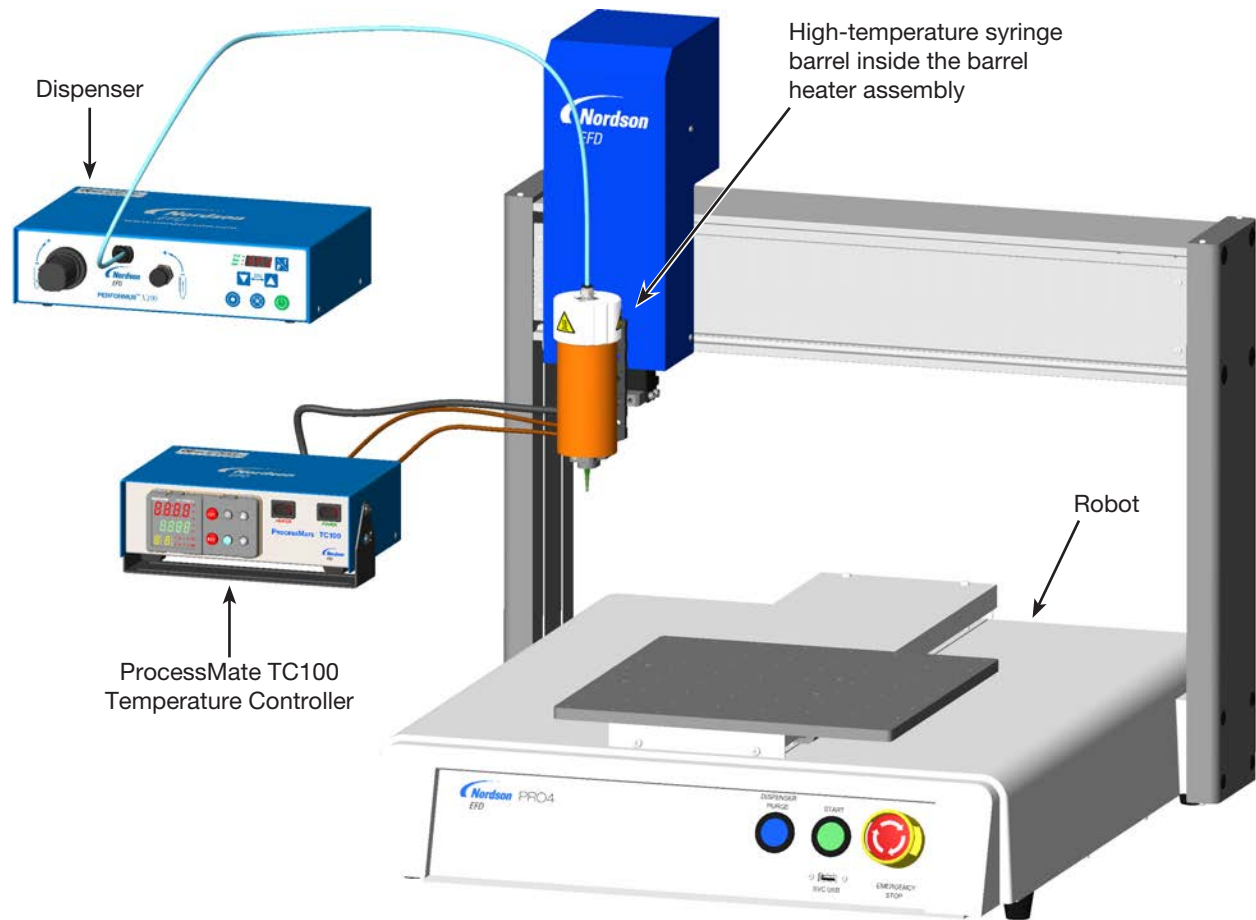

Setup

- Place the POWER switch in the ON position:
 - The red LEDs show the actual temperature as measured by the embedded thermocouple (TC1).
 - The green LEDs show the user-programmed temperature setpoint.

If the display does not appear to show correct values, ensure that the two thermocouple cables are correctly connected to the back of the TC100 controller.

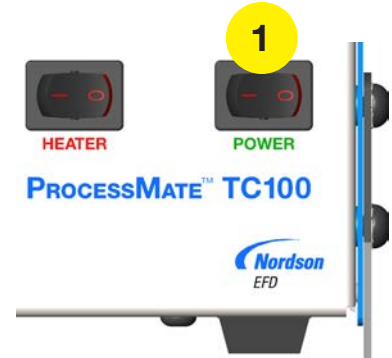

TC1 (red): Actual temperature
(as measured by the thermocouple embedded in the heater sleeve)

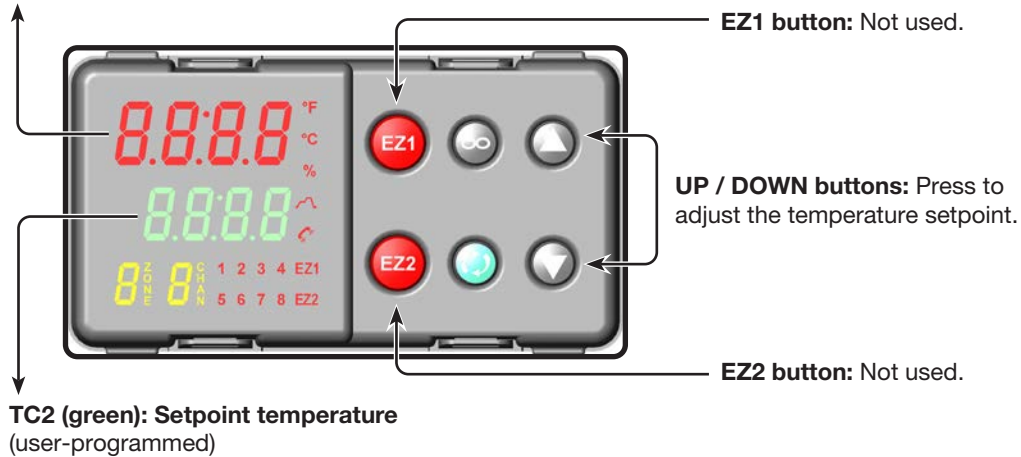

WARNING

Do not exceed the rated TEMPERATURE limit of the syringe barrel.

- Press the UP / DOWN buttons to adjust the temperature setpoint. The green LEDs change to show the new setpoint.

NOTE: The upper temperature setpoint limit is 100° C (212° F). Additionally, do not exceed the rated temperature limit of the Unity HiTemp barrel. Refer to the Unity HiTemp barrel data sheet for limits.

WARNING

Do not exceed the rated PRESSURE limit of the syringe barrel.

- Set the dispensing control device to supply air to the system at the required time and pressure. Refer to the operating manual for the control device as needed.

NOTE: Do not exceed the rated pressure limit of the Unity HiTemp barrel. Refer to the Unity HiTemp barrel data sheet for limits.

Setup (continued)

- On the back of the TC100 controller, place the HEATER switch in the ON position.

The heater begins heating the interior of the heater sleeve to the temperature setpoint.

NOTE: The red temperature LEDs continue to display the actual temperature of the heater. In addition, whenever power is applied to the heater, the number 1 appears next to the channel display. After the heater switches off or reaches a stable temperature, the heater power indication turns off.

- When the desired temperature setpoint is achieved, test the dispensing process. Observe the system for any possible leaks and stop the system immediately if any leakage occurs.
- Continue to the next procedure for routine operation.

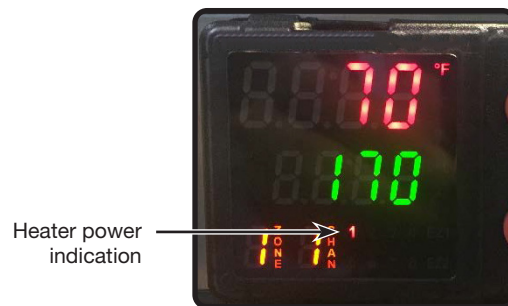
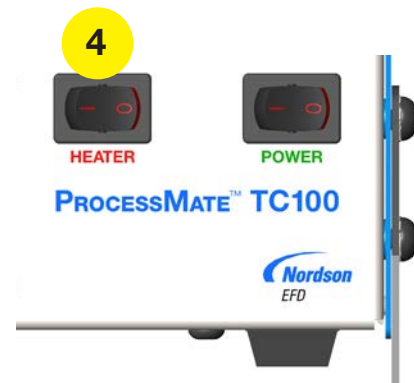

Operation

Startup

- Switch on the system, referring to other component operating manuals (such as the robot and dispenser manuals) as needed.
- On the back of the TC100 controller, place the HEATER switch in the ON position and wait until the temperature setpoint is achieved.
- Run the dispensing process. During routine operation, watch for leaks and stop the system immediately if any leakage occurs.

Shutdown

WARNING

Risk of burns. Do not disassemble the barrel heater or remove the syringe barrel until the system is completely cooled.

- After dispensing is complete, place the TC100 controller HEATER switch in the OFF position.
Allow the entire barrel heater assembly to cool before disassembling the system or removing the barrel from the retainer.
- Shut down the system, referring to other component operating manuals (such as the robot and dispenser manuals) as needed.

Part Numbers

ProcessMate TC100 Temperature Controller and Barrel Heater

Part #	Description
7364017	ProcessMate TC100 Temperature Controller and syringe barrel heater system (includes the TC100 Controller, the barrel heater assembly components, a pack of Unity HiTemp syringe barrels, and a pack of neoprene pistons)

Unity HiTemp Syringe Barrels

Unity HiTemp syringe barrels are engineered using proprietary materials that allow them to withstand high temperatures for up to eight hours. For additional information and component part numbers, refer to the Unity HiTemp data sheet: www.nordsonefd.com/UnityHiTempBarrels

Neoprene Piston

Part #	Description
7015479	Piston, neoprene, 30cc (pack of 20)

Replacement Parts

Part #	Description
7364037	ProcessMate TC100 Temperature Controller
7364038	Syringe barrel retainer
7364161	Heater sleeve (thermocouple cable = 3 m / 9.8 ft)

Troubleshooting

Problem	Possible Cause	Corrective Action
Controller frequently indicates an error	Thermocouple cable loose or damaged	Ensure that both thermocouple cables are securely connected. If either thermocouple cable is loose or not connected, the controller detects an error and will not heat the unit.
	A system component is over-temperature	Ensure that all system components are operating within acceptable temperature limits.
Heater not warming up	Heater power switched off or heater cable loose or damaged	Ensure that the Heater Power switch is in the ON position and that the heater cable is securely connected and not damaged. NOTE: If the actual temperature displayed by the red LEDs is below the setpoint temperature, then the red 1 next to the channel indicator should blink or stay on, indicating that the controller is supplying power to the heater.

NORDSON EFD ONE YEAR LIMITED WARRANTY

This Nordson EFD product is warranted for one year from the date of purchase to be free from defects in material and workmanship (but not against damage caused by misuse, abrasion, corrosion, negligence, accident, faulty installation, or by dispensing material incompatible with equipment) when the equipment is installed and operated in accordance with factory recommendations and instructions.

Nordson EFD will repair or replace free of charge any defective part upon authorized return of the part prepaid to our factory during the warranty period. The only exceptions are those parts which normally wear and must be replaced routinely, such as, but not limited to, valve diaphragms, seals, valve heads, needles, and nozzles.

In no event shall any liability or obligation of Nordson EFD arising from this warranty exceed the purchase price of the equipment.

Before operation, the user shall determine the suitability of this product for its intended use, and the user assumes all risk and liability whatsoever in connection therewith. Nordson EFD makes no warranty of merchantability or fitness for a particular purpose. In no event shall Nordson EFD be liable for incidental or consequential damages.

This warranty is valid only when oil-free, clean, dry, filtered air is used, where applicable.



For Nordson EFD sales and service in over 40 countries, contact Nordson EFD or go to www.nordsonefd.com.

Global

800-556-3484; +1-401-431-7000
info@nordsonefd.com

Europe

00800 7001 7001
infoefd.europe@nordsonefd.com

Asia

China: +86 (21) 3866 9006; china@nordsonefd.com
India: +91 80 4021 3600; india@nordsonefd.com
Japan: +81 03 5762 2760; japan@nordsonefd.com
Korea: +82-31-736-8321; korea@nordsonefd.com
SEAsia: +65 6796 9522; sin-mal@nordsonefd.com

The Wave Design is a trademark of Nordson Corporation.
©2021 Nordson Corporation 7364085 v013021